

# BUILT-IN BOBCAT X-CHANGE SYSTEM

The **RAGNARTECH TILTROTATOR SERIES** is designed to be cost-effective, compact and strong, with machine-specific quick couplings at the top and bottom. It allows the machine thumb to remain in place, while two double-acting cylinders provide ample force up to 50 degrees in each direction.

The rotation device is bolted onto each TiltRotator for full continuous 360-degree rotation, with easy installation requiring only 2 hydraulic circuits and no electric controls involved. This makes them suitable for wet and submerged work, and are specifically designed to utilize the iDig guidance system.

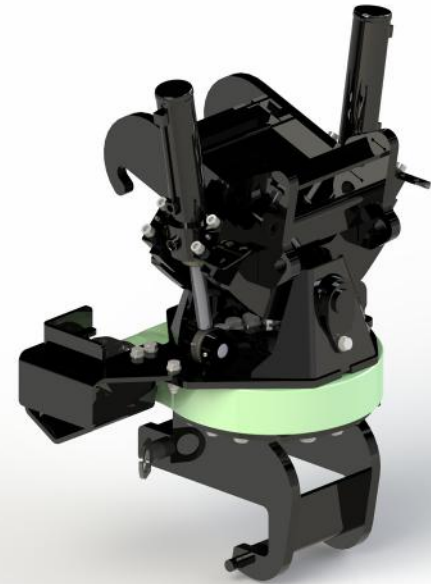

4-6 TONS | 402 LBS



◀ READ MORE HERE

# CHIPPERS

# RAGNARTECH

Practica Novitates

# ATTACHMENTS

Innovative Products for the Construction & Forestry Industries

RagnarTech attachments are designed to go on a variety of machines, including: BobCat, Kubota, CAT, John Deere, Hitachi, and many more.

RagnarTech has a full line of high-quality, high-performance tree care chippers, serving as the exclusive US dealer for the European manufacturer, Ufkes Greentec. Distributor inquires welcome.



2636



2242



1828



1624



**NEW!** UPDATED PRODUCTS & MODEL NUMBERS

COMPACT • POWERFUL • PRODUCTIVE  
WITH ADVANCED DESIGN AND QUALITY CONSTRUCTION



Prepared for both iDig and TopCon excavator guidance systems that are both very cost effective and easy to install and use.



**RAGNARTECH**  
Practica Novitates

**RAGNARTECH**  
Practica Novitates

RAGNARTECH-INC.COM • INFO@RAGNARTECH-INC.COM  
603.244.7575 • 44 IRON HORSE DRIVE, FREMONT NH 03044

IMPROVING YOUR

**RAGNARTECH**  
Practica Novitates

BOBCAT EXPERIENCE



# GRAPPLE SHEARS

**GRAPPLE SHEARS** are constructed from durable Hardox material for efficient and reliable timber harvesting. Bolt-on blade can be quickly swapped out to provide a dedicated grapple device.

**OPTIONAL:**

- ▶ 360-degree rotator
- ▶ Collector attachment enables the operator to securely grasp small trees while opening the grapple to make the next cut
- ▶ Hydraulic bar saw option available for the 250 and 300 models for up to 24" cuts
- ▶ Separate Circuit Dual Guillotine knives for larger diameter and controlled shearing



◀ **READ MORE HERE**



| MODEL                   | 200     | 250      | 300       | 400       |
|-------------------------|---------|----------|-----------|-----------|
| <b>WITHOUT OPTIONS</b>  | 545 lbs | 790 lbs  | 1,256 lbs | 4,300 lbs |
| <b>CUTTING DIAMETER</b> | 8"      | 10"      | 12"       | 18"       |
| <b>GRAPPLE OPENING</b>  | 24"     | 28"      | 33"       | 40"       |
| <b>EXCAVATORS</b>       | 2-5 ton | 6-12 ton | 12-20 ton | 25-35 ton |

# SPLITMAX

The **SPLITMAX** series is designed for excavators from 8-40 tons, allowing for easy attachment in minutes via a machine specific coupler. The heavy duty construction utilizes high tensile and abrasive resistant steel to ensure versatility and durability. Dual 5000psi hydraulic cylinders make splitting the largest logs and stumps effortless, while the large hardened pins and bushing with line bored construction ensures a perfect fit. Additionally, a backplate allows for grading and pushing material, and options such as bolt-in replaceable tips and a wear liner if used to excavate stumps are available. The machine mounting bracket is easily adaptable to any style quick disconnect coupling and machine, while all high forces are internally contained, causing no stress on the machine.



◀ **READ MORE HERE**



| MODEL                   | SM30     | SM48      | SM60      |
|-------------------------|----------|-----------|-----------|
| <b>WEIGHT (LBS)</b>     | 1,450    | 3,200     | 4,600     |
| <b>OPENING DIAMETER</b> | 30"      | 48"       | 60"       |
| <b>CYLINDER BORE</b>    | 4" bore  | 5" bore   | 6" bore   |
| <b>EXCAVATORS</b>       | 6-12 ton | 14-30 ton | 25-40 ton |

# GRADING BUCKETS

|               | 4-TON      | 6-TON      | 8-TON      |
|---------------|------------|------------|------------|
| <b>VOLUME</b> | 175-Liters | 240-Liters | 300-Liters |
| <b>WIDTH</b>  | 44"        | 48"        | 52"        |
| <b>TEETH</b>  | Hardox 450 | Hardox 450 | Hardox 450 |

Tapered For Use With TiltRotator

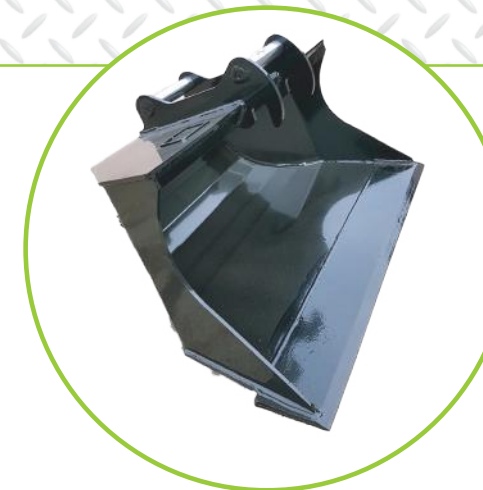

# DIGGING BUCKETS

|               | 4-TON      | 6-TON      | 8-TON      |
|---------------|------------|------------|------------|
| <b>VOLUME</b> | 200-Liters | 285-Liters | 380-Liters |
| <b>WIDTH</b>  | 25.6"      | 29.5"      | 31.5"      |
| <b>TEETH</b>  | J200       | J200       | J250       |



# SAWMASTER

The **SAWMASTER** grapple and bar saw are designed for telehandlers, excavators, and a variety of other construction equipment. With a cutting capacity up to 40 inches the SawMaster is a strong and tested grapple with a variety of quick disconnects available. Ideal for land clearing, pruning, roadside vegetation management, pasture edge maintenance, and forest thinning.



◀ **READ MORE HERE**



| MODEL                   | 1200  | 1600  | 2000   |
|-------------------------|-------|-------|--------|
| <b>WEIGHT (LBS)</b>     | 2,200 | 2,700 | 3,200  |
| <b>MAX LOAD (LBS)</b>   | 5,500 | 9,000 | 13,000 |
| <b>CUTTING DIAMETER</b> | 24"   | 28"   | 40"    |

# GRAPPLES

Ragnartech's fixed 360-degree rotation **GRAPPLES** are constructed from highly durable Hardox Steel, featuring parts common to the JAK shear base platform. The grapples are extremely rugged, preventing deformation of the open grapple arms, while optional knives can be inserted for cutting wood. The excavator mounting bracket is bolted on and designed for all types of configurations. Optional angular excavator brackets are available for transforming the grapple into a powerful harvesting tool. Dual high-pressure cylinders offer immense clamping force, making this Grapple a versatile and reliable tool.



◀ **READ MORE HERE**



| MODEL                   | 200           | 250      | 300       | 400       |
|-------------------------|---------------|----------|-----------|-----------|
| <b>WEIGHT (LBS)</b>     | 595           | 2,700    | 3,200     | 3,200     |
| <b>WORKING PRESSURE</b> | 3000-4500 PSI |          |           |           |
| <b>GRAPPLE OPENING</b>  | 24"           | 28"      | 33"       | 40"       |
| <b>EXCAVATORS</b>       | 4-6 ton       | 8-12 ton | 12-25 ton | 25-35 ton |

# LOGBUDDY

Extends the reach and improves the handling and stacking of logs / trees while facilitating quick and easy connection of a log grapple. Available with optional rotator and grapples to fit all excavators and material handlers from 5-40 ton. Custom versions available for skid steer machines as well.



# GRADING BEAM

The Ragnartech Grading Beam is designed with Hardox for exceptional durability and strength. It is easy to connect with a machine specific bolt on mounting bracket, and features dual grading edges with one side for scooping material.

